

# PS1112S

**+12V@1.2A Low-Noise  
Power Supply**



## User's Manual



LOW-NOISE FIXED VOLTAGE AC/DC

All Rights Reserved  
© CAEN ELS s.r.l.  
Rev. 1.5 – November 2022



**CAEN ELS s.r.l.**

c/o AREA Science Park  
S.S. 14 km 163,5 – 34149 Basovizza (TS)  
Italy

Mail: [info@caenels.com](mailto:info@caenels.com)

Web: [www.caenels.com](http://www.caenels.com)

*Registered office: via Vetraia 11, 55049 – Viareggio (LU) - Italy*



# Table Of Contents

<b>1. INTRODUCTION.....</b>	<b>10</b>
1.1 THE PS1112S POWER SUPPLY .....	10
1.2 THE PS1112S AT A GLANCE .....	11
1.3 TECHNICAL DATA .....	12
<b>2. SAFETY.....</b>	<b>13</b>
2.1 INJURY PRECAUTIONS .....	13
2.2 CAUTION.....	13
2.3 INPUT RATINGS .....	14
2.4 LIVE CIRCUITS .....	14
2.5 PART REPLACEMENT AND MODIFICATIONS .....	14
<b>3. I/O CONNECTORS.....</b>	<b>15</b>
3.1 AC LINE INPUT CONNECTOR .....	15
3.2 OUTPUT .....	16
3.3 STATUS LED.....	17
3.4 FIXING .....	17
3.5 MOUNTING POSITION .....	18
<b>4. TECHNICAL SPECIFICATIONS .....</b>	<b>20</b>
<b>5. MECHANICAL DIMENSIONS.....</b>	<b>21</b>
<b>6. OUTPUT CURRENT DERATING.....</b>	<b>22</b>
<b>7. ORDERING CODES.....</b>	<b>23</b>



## Document Revisions

Document Revision	Date	Comment
1.0	October 24 <sup>th</sup> , 2014	First Release
1.1	October 29 <sup>th</sup> , 2014	Manual graphics changed
1.2	December 2 <sup>nd</sup> , 2014	Updated the pin-out of the Output DC connector to match the names used in the datasheet
1.3	December 30 <sup>nd</sup> , 2014	Updated ordering option Table
1.4	October 14 <sup>th</sup> , 2020	Data correction on maximum output power
1.5	November 22 <sup>nd</sup> , 2022	Added UKCA compliance logo



## Safety information - Warnings

CAEN ELS will repair or replace any product within the guarantee period if the Guarantor declares that the product is defective due to workmanship or materials and has not been caused by mishandling, negligence on behalf of the User, accident or any abnormal conditions or operations.

**Please read carefully the manual before operating any part of the instrument**



### **High voltage inside, do NOT open the boxes**

**CAEN ELS d.o.o. declines all responsibility for damages or injuries caused by an improper use of the Modules due to negligence on behalf of the User. It is strongly recommended to read thoroughly this User's Manual before any kind of operation.**

CAEN ELS d.o.o. reserves the right to change partially or entirely the contents of this Manual at any time and without giving any notice.

#### **Disposal of the Product**

The product must never be dumped in the Municipal Waste. Please check your local regulations for disposal of electronics products.



Read over the instruction manual carefully before using the instrument.  
The following precautions should be strictly observed before using the PS1112S:

---

**WARNING**

- Do not use this product in any manner not specified by the manufacturer. The protective features of this product may be impaired if it is used in a manner not specified in this manual.
- Do not use the device if it is damaged. Before you use the device, inspect the instrument for possible cracks or breaks before each use.
- Do not operate the device around explosives gas, vapor or dust.
- Always use the device with the cables provided.
- Turn off the device before establishing any connection.
- Do not operate the device with the cover removed or loosened.
- Do not install substitute parts or perform any unauthorized modification to the product.
- Return the product to the manufacturer for service and repair to ensure that safety features are maintained

---

**CAUTION**

- This device is designed for indoor use and in area with low condensation.



The following table shows the general environmental requirements for a correct operation of the instrument:

<b>Environmental Conditions</b>	<b>Requirements</b>
Operating Temperature	0°C to 50°C
Operating Humidity	30% to 85% RH (non-condensing)
Storage Temperature	-10°C to 60°C
Storage Humidity	5% to 90% RH (non-condensing)

# 1. Introduction

This chapter describes the general characteristics and main features of the PS1112S low-noise power supply.

## 1.1 The PS1112S Power Supply

CAEN ELS PS1112S is a single-output +12V mixed switching-linear power supply that is designed in order to obtain low-noise operation and high efficiency and it is especially suited for measurement systems where switching power supplies could corrupt measuring noise, accuracy and precision.

The power supply is housed in a robust and compact stainless-steel box that can be placed next to the supplied device in order to reduce cable lengths and minimize consequent possible noise pick-up.

These power supplies are particularly designed for operation with the following CAEN ELS devices:

- **TetrAMM Picoammeter**
- **PreDAC**

All the above cited devices, combined with a PS1112S low-noise voltage power supply, guarantee their rated specifications.

## 1.2 The PS112S at a Glance

The PS112S linear power supply and its I/Os are represented in **Figure 1**:



**Figure 1:** overall view of a PS112S power supply

The PS112S is an isolated power supply, with a 3-pole output connector, specifically designed to supply low current and precision instrumentation.

The AC Power Line input is placed on the left side of the box while the output connectors on the right side; LED monitor (indicating the presence of the output voltage) is placed on the front side.

The PS112S has a standard +12V output voltage, as indicated in the following **Table 1**:

	Positive Output Voltage
PS112S	+12 V; 1.2A

**Table 1:** output voltage and current values

### 1.3 Technical Data

The PS1112S power supply has an output voltage accuracy of  $\pm 3\%$  - i.e. from 11.64 V to 12.36 V.

Maximum peak-to-peak voltage noise measured at the device output terminals is rated at 4 mV. This value is measured over a 1 MHz bandwidth using a LeCroy MSO 44MXs-B, 400MHz, 5GS/s with AC Coupling at full load. A typical output waveform used to estimate the peak to peak noise value is shown in **Figure 2**.

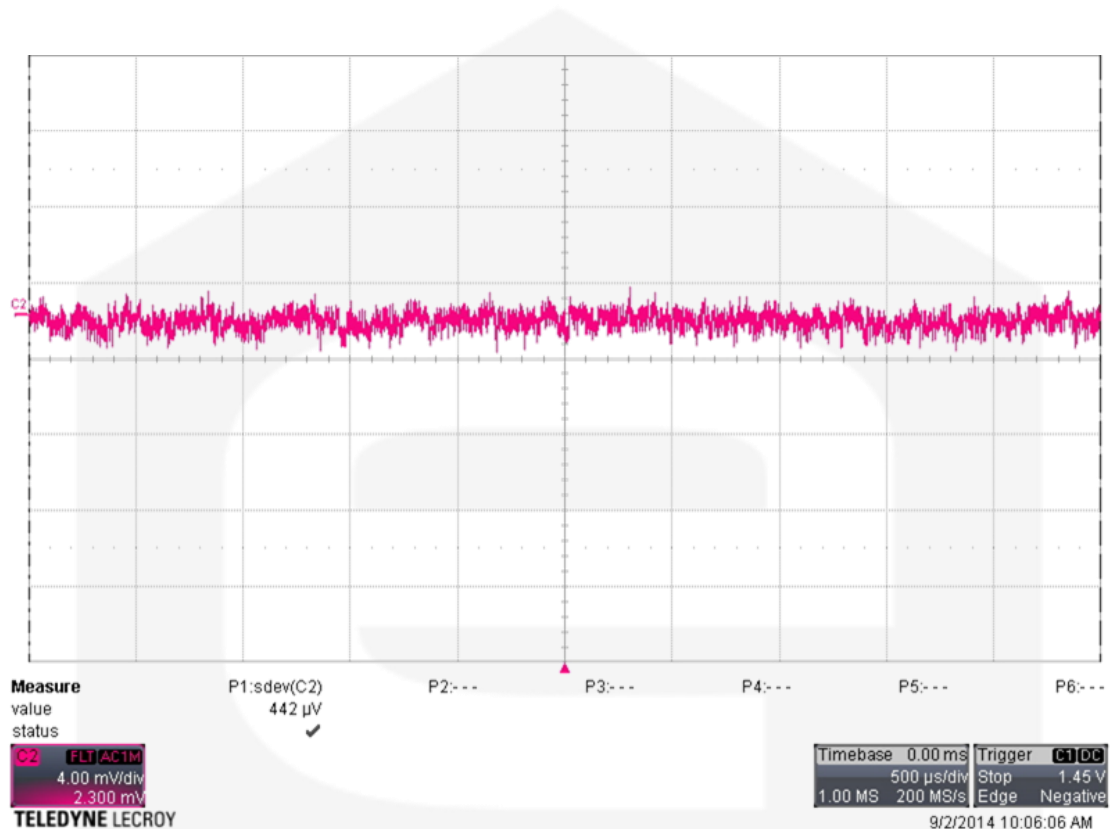

**Figure 2:** typical output noise - AC coupling

The PS1112S outputs are floating respect Earth up to 500V, protected against short-circuit and from over-voltage.

## 2. Safety

### 2.1 Injury Precautions

Prior to shipment this system was inspected and found free of mechanical or electrical defects. Upon unpacking of the system, inspect for any damage, which may have occurred in transit. The inspection should confirm that there is no exterior damage to the system such as broken connectors.

This section contains the fundamental safety rules for the installation and operation of the system. Read thoroughly this section before starting any procedure of installation or operation.

### 2.2 Caution

The following safety precautions must be observed during all phases of operation, service and repair of this equipment. Failure to comply with the safety precautions or warnings in this document violates safety standards of design, manufacture and intended use of this equipment and may impair the built-in protections within.

CAEN ELS d.o.o. shall not be liable for user's failure to comply with these requirements.

To avoid electrical shock or fire hazard, do not apply a power to a load that is outside the rated conditions.

**Do Not Operate Without Covers.**

To avoid electric shock or fire hazard, do not operate this product with covers or panels removed.

**Do Not Operate in Wet/Damp Conditions.**

To avoid electrical shock, do not operate this product in wet or damp conditions.

**Do Not Operate in an Explosive Atmosphere.**

To avoid injury or fire hazard, do not operate this product in an explosive atmosphere.

**Do Not Operate With Suspected Failures.**

If you suspect there is damage to this product, have it inspected by qualified service personnel.

## 2.3 Input Ratings

Do not use AC supply which is outside the limits for the input voltage and frequency ratings of this instrument. For input voltage and frequency rating of the module see **Table 3**. For safety reasons, the mains supply voltage fluctuations should not exceed above voltage range.

## 2.4 Live Circuits

No internal adjustment or component replacement is allowed to non-CAEN ELS d.o.o. personnel. Never replace components with power cables connected.

In order to avoid injuries, always disconnect power plugs, let circuits discharge and remove external voltage source before touching components (wait 10 min at least).

## 2.5 Part Replacement and Modifications

Parts substitutions and modifications are allowed by authorized CAEN ELS d.o.o. service personnel only.

## 3. I/O Connectors

This chapter describes the I/O connectors, their corresponding pinout and their functionality.

### 3.1 AC Line Input Connector

The AC Line Input connector is in a standard IEC Male Socket as shown in **Figure 3**.

The PS1112S power supply is designed for universal AC input voltage range since it can operate with voltage from 90V to 260V and input frequency from 47 to 63 Hz. Under the value of 115V AC Mains input the Power Supply is subject to current (i.e. power) de-rating. See **Output Current Derating** chapter for further details.



**Figure 3:** AC Line input connector

## 3.2 Output

Output DC voltage is made available through a 3-pole connector with a screw locking. The pin-out of the connector (frontal view) is shown in **Figure 4**.

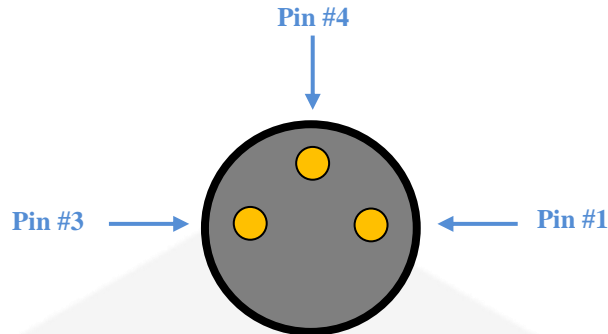

**Figure 4:** Output DC Connector (TE 1838839-1)

The output connector has the following pin-out:

<i>Pin #</i>	<i>PS1112S</i>
1	+12V
3	nc
4	GND

**Table 2:** PS1112S output D connector pin-out

In the same package of the power supply PS1112S there is also a mating un-terminated cable that can be terminated with the desired connector.



### 3.3 Status LED

On a lateral side of the power supply, two LEDs turn off whenever the +12V is not correctly regulated on the output cable.



Figure 5: LED indicators for output voltage

### 3.4 Fixing

On the bottom side of the PS1112S four threaded M3×4mm holes can be used for fixing the power supply. These are indicated in the following Figure 6.

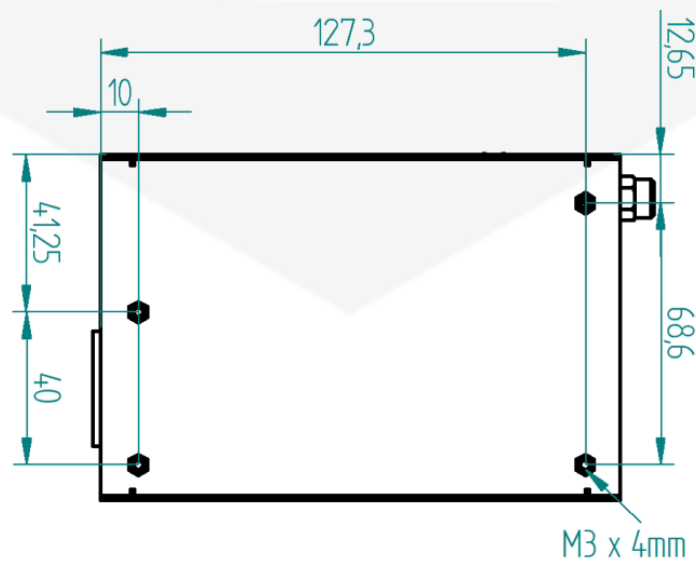

Figure 6: Threaded holes position on the PS1112S bottom

### 3.5 Mounting position

PS1112S shall **NOT be mounted** in the two following positions:

- bottom side of the box fixed to the ceiling (**Figure 7**);
- lateral side of the box that present ten ventilation holes faced to the top (**Figure 8**).

The RECOMMENDED mounting positions for increasing the heat dissipation and increasing reliability and life-time are:

- bottom side of the box fixed to the floor;
- lateral side of the box that present twenty ventilation holes faced to the top.

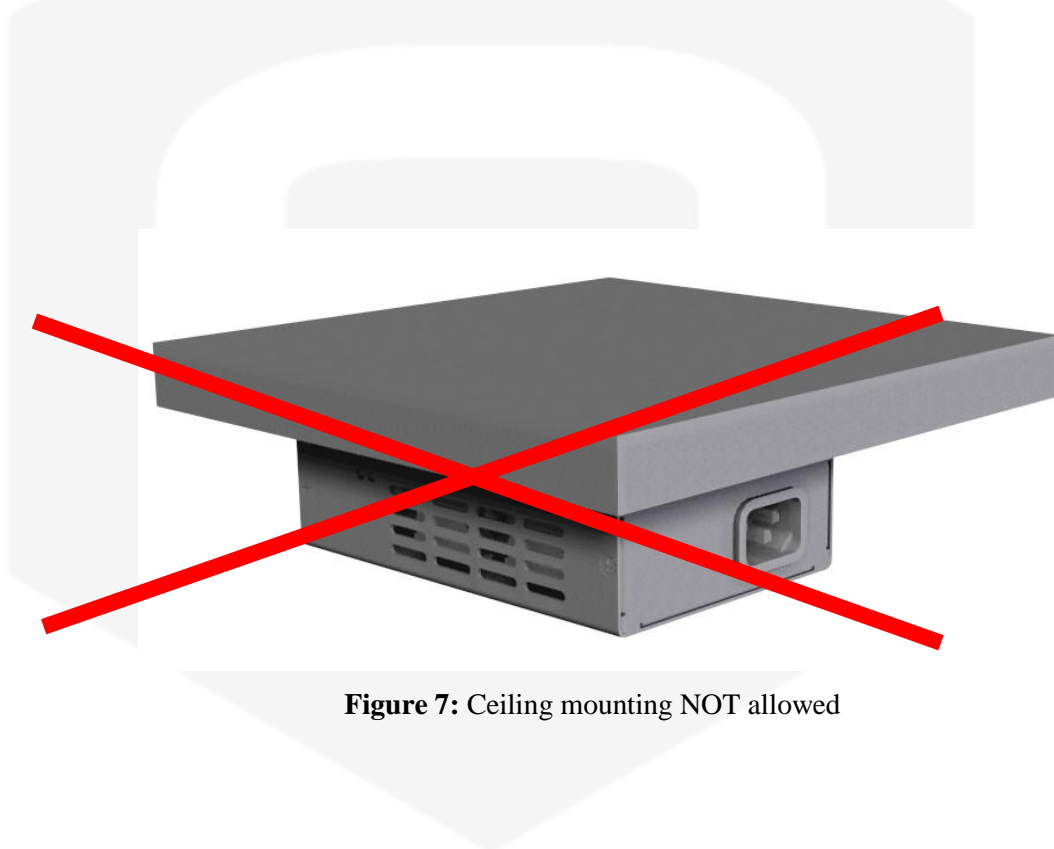

**Figure 7:** Ceiling mounting NOT allowed

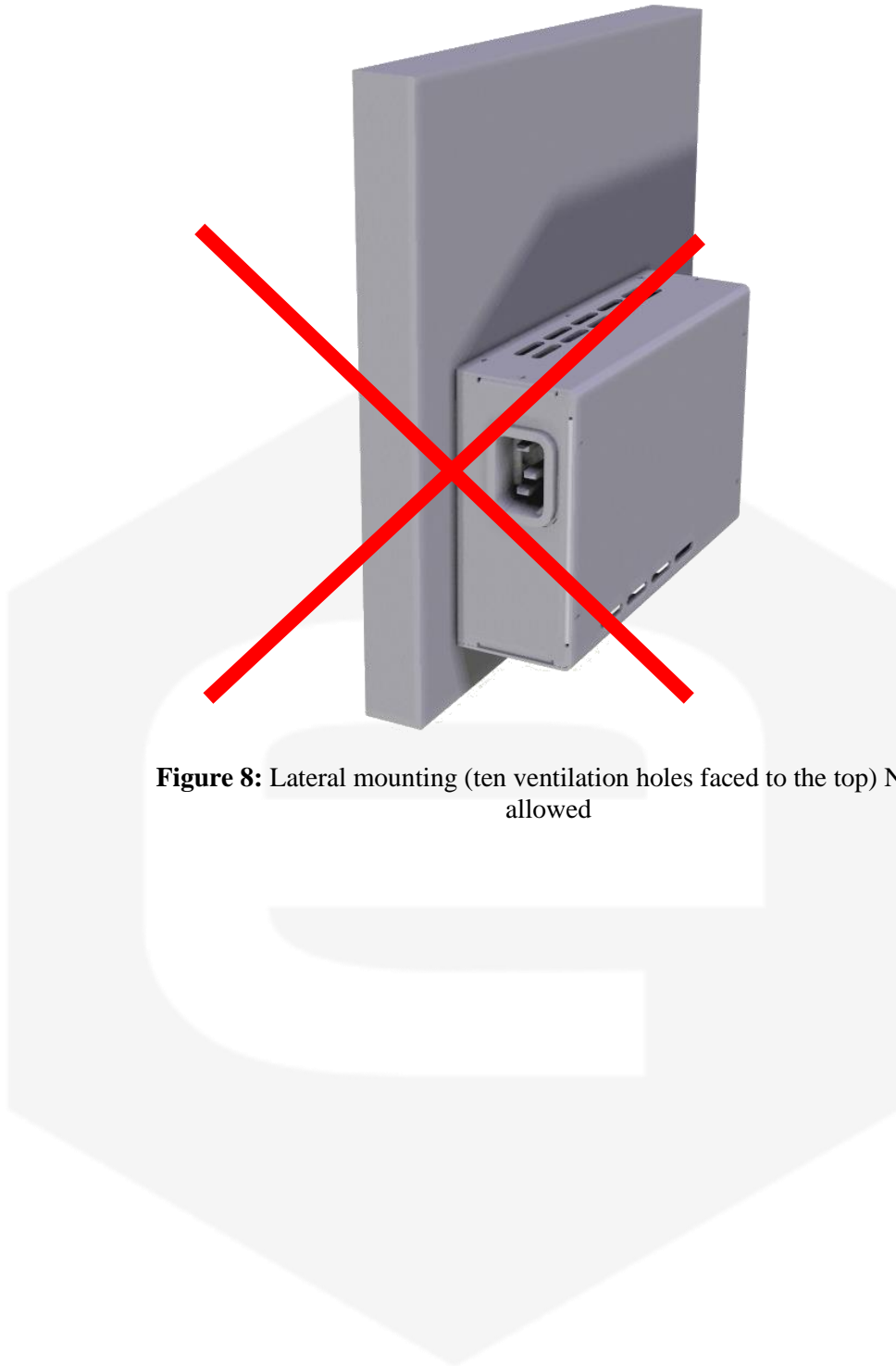

**Figure 8:** Lateral mounting (ten ventilation holes faced to the top) NOT allowed

## 4. Technical Specifications

Technical Specifications for the PS1112S linear power supplies are presented in the following **Table 3**.

Technical Specifications	PS1112S
Output Voltage ( $\pm 3\%$ )	+12 V
Maximum Output Power	14.4 W
Maximum Output Current	+12V @ 1.2 A
Output Ripple + Noise	0.003% <sub>RMS</sub> @ DC-1MHz 0.025% <sub>P-P</sub> @ DC-1MHz
AC Line Voltage Input	90 – 260 V <sub>AC</sub>
AC Line Frequency	47 - 63 Hz
Input to Output Isolation	3kV
Output to Earth-Case Isolation	500V
Hold-up time	16 ms typ. at 115 V <sub>AC</sub>
Cooling	Natural convection
Dimensions	136.4 × 41 × 90.7 mm
Weight	600 g
Y-Cable length (CT-I and CT-V)	3m
Indicators	1 LED (Power Good)
Protections	Output short-circuit Output over-voltage
Operating Temperature Range	0°C – 50°C

**Table 3:** PS1112S power supply main specifications

## 5. Mechanical Dimensions

The PS1112S low-noise power supply mechanical dimensions are hereafter shown:

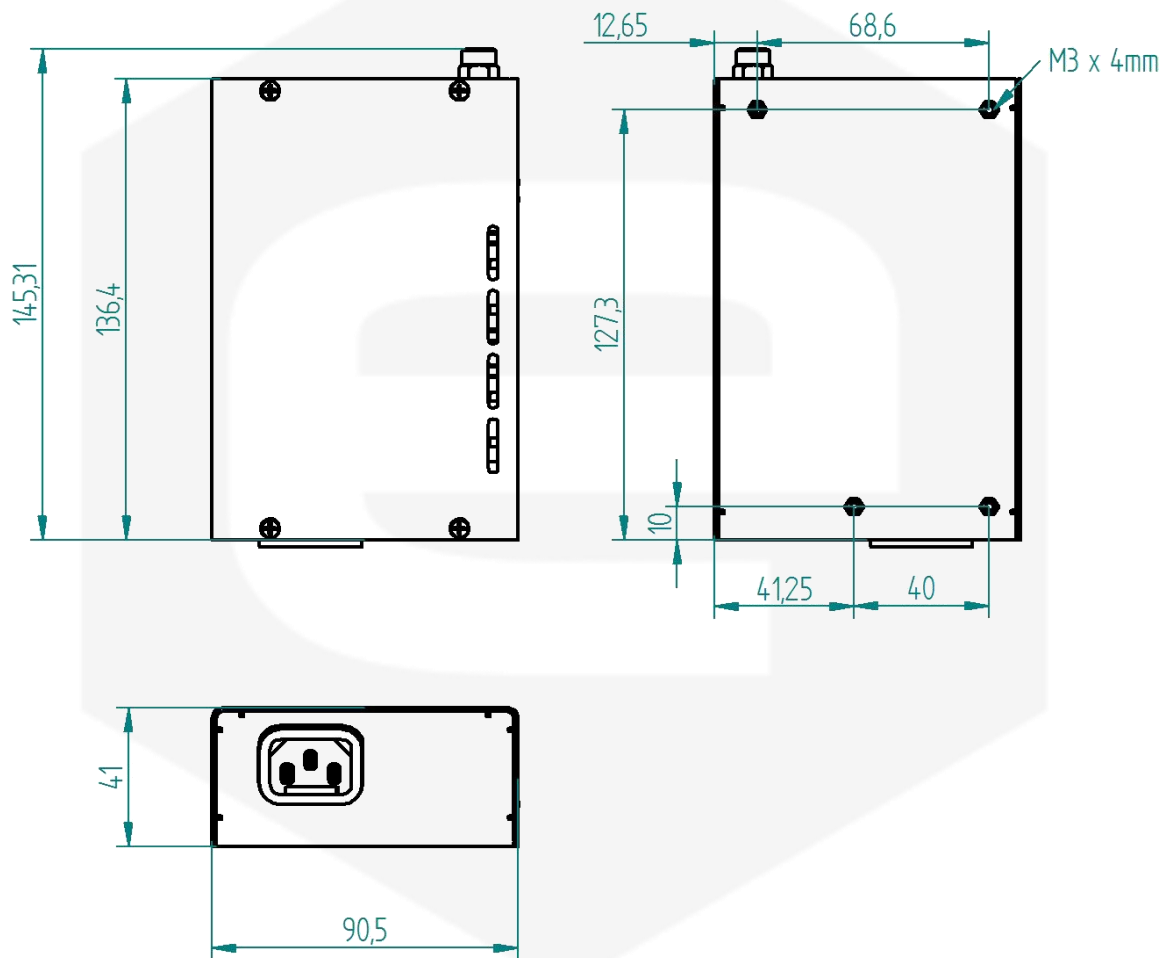

Figure 9: Mechanical drawings

## 6. Output Current Derating

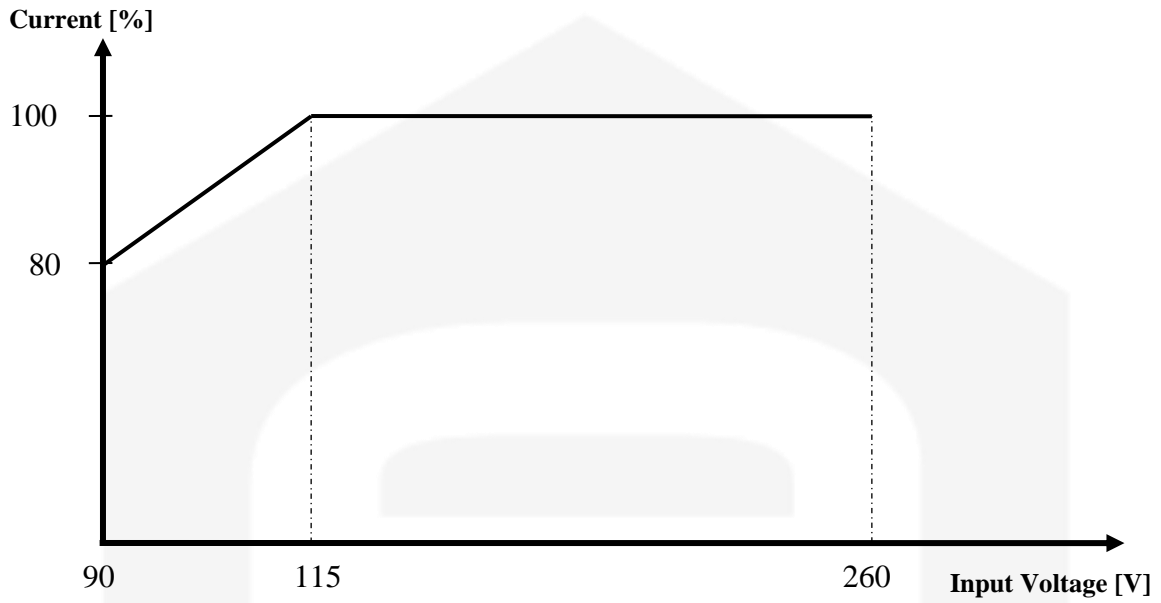

Figure 10: Output Current vs Input Voltage at 60 Hz

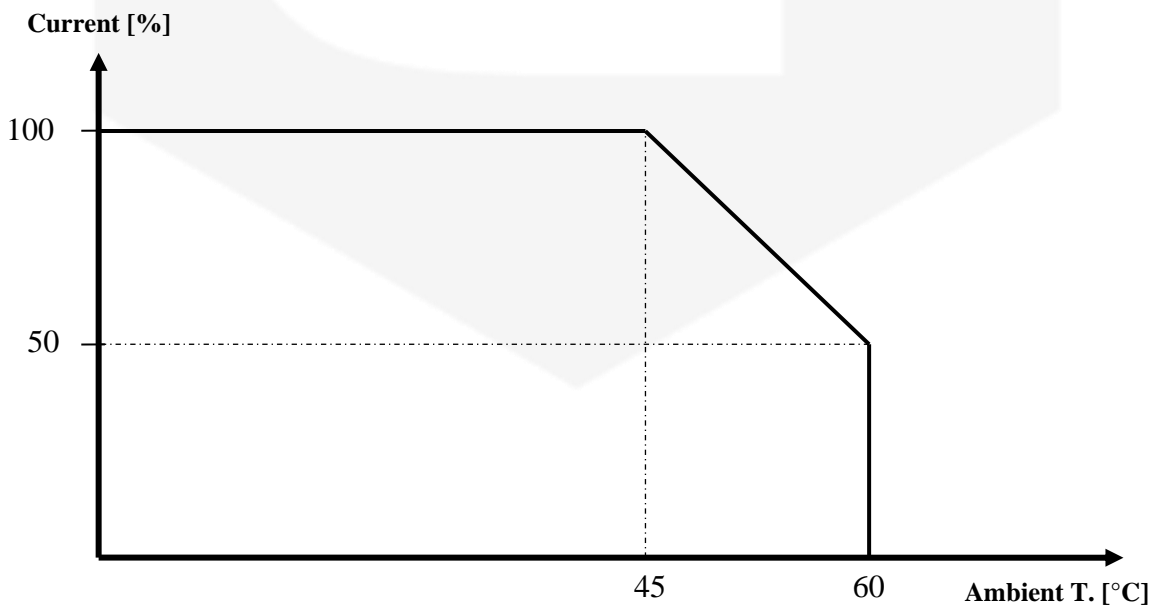

Figure 11: Output Current vs Ambient Temperature

## 7. Ordering Codes

The PS1112S power supply can be ordered using the following ordering codes:

<i>Model</i>	<i>Ordering Code</i>	<i>Description</i>
PS1112S	WPS1112SXAAA	<i>PS1112S - AC/DC Single Output - Single Voltage +12V Low Noise Power Supply – 14.4W max, with 5m un-terminated cable</i>
PS1112S-T	WPS1112STXAA	<i>PS1112S - AC/DC Single Output - Single Voltage +12V Low Noise Power Supply – 14.4W max, with 1.5m power jack 2mm cable</i>